

**Interface Document  
BID-0015  
October 1994**

**Network Portability Access Service (NPAS)  
and Universal Voice Messaging Service (UVMS)  
  
Terminal-to-Network Interface**

**This document cannot be reproduced without the express permission of Bell Canada  
Any reproduction, without authorization, is an infringement of Bell Canada's copyright.**

**Copyright ©  
Bell Canada  
1994  
All Rights Reserved**

**TABLE OF CONTENTS**

Document History	1
Disclaimer	2
1.0 SERVICE DESCRIPTION	3
1.1 Network Portability Service (NPS)	3
1.2 Universal Voice Messaging Service (UVMS)	3
2.0 FEATURE DESCRIPTION	4
2.1 Interface Description	6
2.2 Service Node Access Channel	7
2.3 Service Node Data Port	7
2.4 Message Waiting Indication	7
2.5 Voice Message Deposit	7
2.6 Voice Message Retrieval	7
3.0 PHYSICAL CHARACTERISTICS OF THE SMDI INTERFACE	8
3.1 SMDI Data Interface	8
3.2 Timing Information	9
3.3 Additional Options Available for SMDI Data Interface	9
3.4 Timing Information	10
4.0 DETAILED DATA PROTOCOL	11
4.1 Characteristics	11

---

4.2	Messages From the Network to the Message Desk	11
4.2.1	Call History Information Messages	11
4.3	Examples of Messages to the Message Desk	13
4.3.1	Maximum Length Message	13
4.3.2	Calling Station ID Unavailable	14
4.3.3	Called Station ID Unavailable	15
4.3.4	Called Station ID and Calling Station ID Unavailable	16
4.4	Failure Messages for MWI Control Capability	17
4.5	Examples of Failure Messages	18
4.5.1	Failure Message (Invalid Station Number or Other Long Term Problem)	18
4.5.2	Failure Message (Blocked for Temporarily Blocked Activity)	19
4.6	Messages From the Message Desk to the Network	20
4.6.1	Request to Activate the MWI	20
4.6.2	Request to Deactivate the MWI	21
5.0	REFERENCES	22

**DOCUMENT HISTORY**

- |       |               |   |
|-------|---------------|---|
| 1     | March 1993    | Initial issue   |
| ----- |               |   |
| 2     | November 1993 | Addition of 2400, 4800, 9600 bit per second transmission speeds.  |
| ----- |               |   |
| 3     | June 1994     | Correction of Binary Code for Control [D] on Pages 20 and 21.<br>Miscellaneous formatting and housekeeping changes. |
| ----- |               |   |
| 4     | October 1994  | Addition of UVMS Service and Feature descriptions.<br>Miscellaneous formatting and housekeeping changes.            |
| ----- |               |   |

RENAMED AS BELL CANADA BID-0015 FROM STENTOR ID-0016

**DISCLAIMER**

Bell Canada reserves the right to modify the interface described in this document for any reason including, but not limited to, ensuring that it conforms with standards promulgated by various agencies from time to time, utilization of advances in the state of the technical arts, or the reflection of changes in the design of any equipment, techniques or procedures described or referred to herein.

**BELL CANADA SHALL NOT BE LIABLE FOR ANY DAMAGES OR INJURIES INCURRED BY ANY LEGAL PERSON OR PERSONS, INCLUDING BUT NOT LIMITED TO CORPORATIONS, ARISING DIRECTLY OR INDIRECTLY FROM A TERMINAL DESIGN INCOMPATIBILITY WITH THE NETWORK, OR ANY CAUSE WHATSOEVER.**

Readers are specially advised that the technical requirements contained herein may change.

If further information is required, please contact:

**BELL CANADA**

Director - Interface Standards Research  
Suite 640  
160 Elgin Street  
Ottawa, Ontario  
K1G 3J4

In Canada:	1-877-77-TELCO (83526)
Worldwide:	613-781-7393
Fax:	613-781-1658
E-mail:	<a href="mailto:disclosure@bell.cdn-telco.com">disclosure@bell.cdn-telco.com</a>
Web-site:	<a href="http://www.bell.cdn-telco.com">http://www.bell.cdn-telco.com</a>

## **1.0 SERVICE DESCRIPTION**

### **1.1 Network Portability Service (NPS)**

The **Network Portability Service (NPS)** allows the users to streamline and direct incoming calls via an assigned single access number to a location be it home, office, voice mail box, etc. The **NPS** lets the subscribers answer their calls at any time and from any telephone set in the network.

The **NPS** service subscribers could, for example, be given a personal number which could allow them to direct the routing of calls to a number of different locations (home, office, mail box, etc.) based on the subscriber's own schedule. The **NPS** subscriber's profile could be changed from any Dual-Tone Multifrequency (DTMF) set. Thus the service could enable the subscribers to have total control over their communications so that they could receive calls when, where and how they wish.

The terminal-to-network interface used for the Network Portability Access Service (**NPAS**) lets the **NPS** service providers interface their **NPS** Service Node with the DMS-100™ switch.

### **1.2 Universal Voice Messaging Service (UVMS)**

Universal Voice Messaging Service (UVMS) provides a mailbox to all telephone subscribers. A caller that reaches a 'busy' or 'no-answer' condition could decide to deposit a voice message. Regular toll charges apply to long distance calls that result in a deposited voice message as well as to long distance calls for the purpose of message retrieval.

This document describes the terminal to network interface which allows a UVMS provider to interface their Service Node with a Northern Telecom DMS-100™ switch.

## 2.0 FEATURE DESCRIPTION

The Service Node could provide a number of capabilities based on this interface specification. For example, direct routing of calls (to home, office, voice mail, etc.) based on time and day of the week, screen incoming calls or page the subscriber. It could be used to provide the subscribers with a Universal Voice Messaging Service (UVMS) for calls which cannot be completed (e.g., busy, no answer). Visual Message Waiting Indication (VMWI) or Audible Message Waiting Indication (AMWI) activation/deactivation requested capability could be designed into a node. If a voice message is deposited, the Service Node can cause the network to activate a subscriber's Message Waiting Indication (MWI), of any type supported by the network. Once the voice message is retrieved the Service Node can cause the network to deactivate MWI.

When a caller accesses the service (using the access method detailed below) the service node may provide the following functionality:

- The Service Node could return OFF-HOOK upon receipt of the call. **(NPS, UVMS)**
- The Service Node could process the call and redirect it to a location defined by the service subscriber's profile. **(NPS)**
- The Service Node could initiate a 3-way conference call request to the DMS-100. **(NPS)**
- The Service Node could send ON-HOOK signal to the DMS-100 to clear down the access to the Service Node. **(NPS, UVMS)**
- The Service Node could facilitate delivery of messages to the subscriber's mail box. **(NPS)**
- The Service Node could receive a call history information message over the Simplified Message Desk Interface (SMDI) link from the DMS-100. **(NPS, UVMS)**
- Upon the presence/absence of messages in the subscriber's mailbox, the Service Node could activate/deactivate the MWI at the subscriber's location using the Simplified Message Desk Interface (SMDI) link from the DMS-100. **(NPS, UVMS)**
- The Service Node could return an OFF-HOOK and output pulse DTMF to initiate an outgoing call. **(UVMS)**

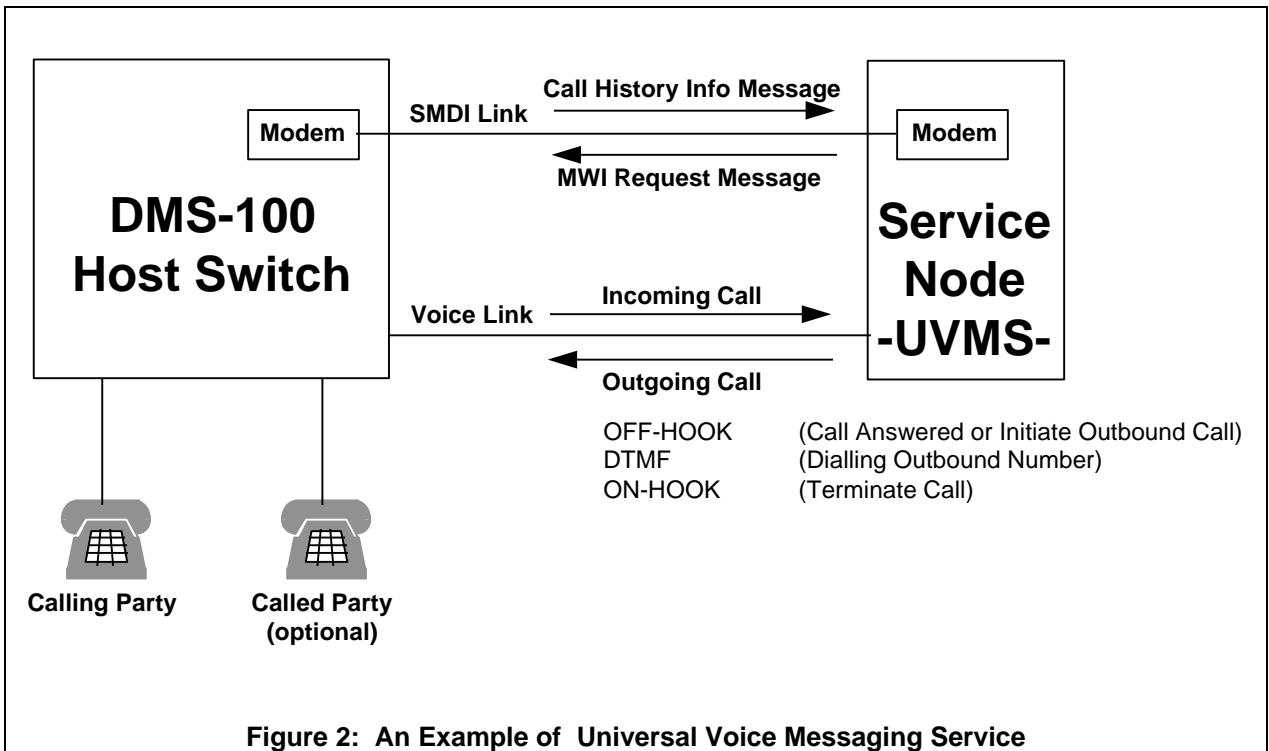
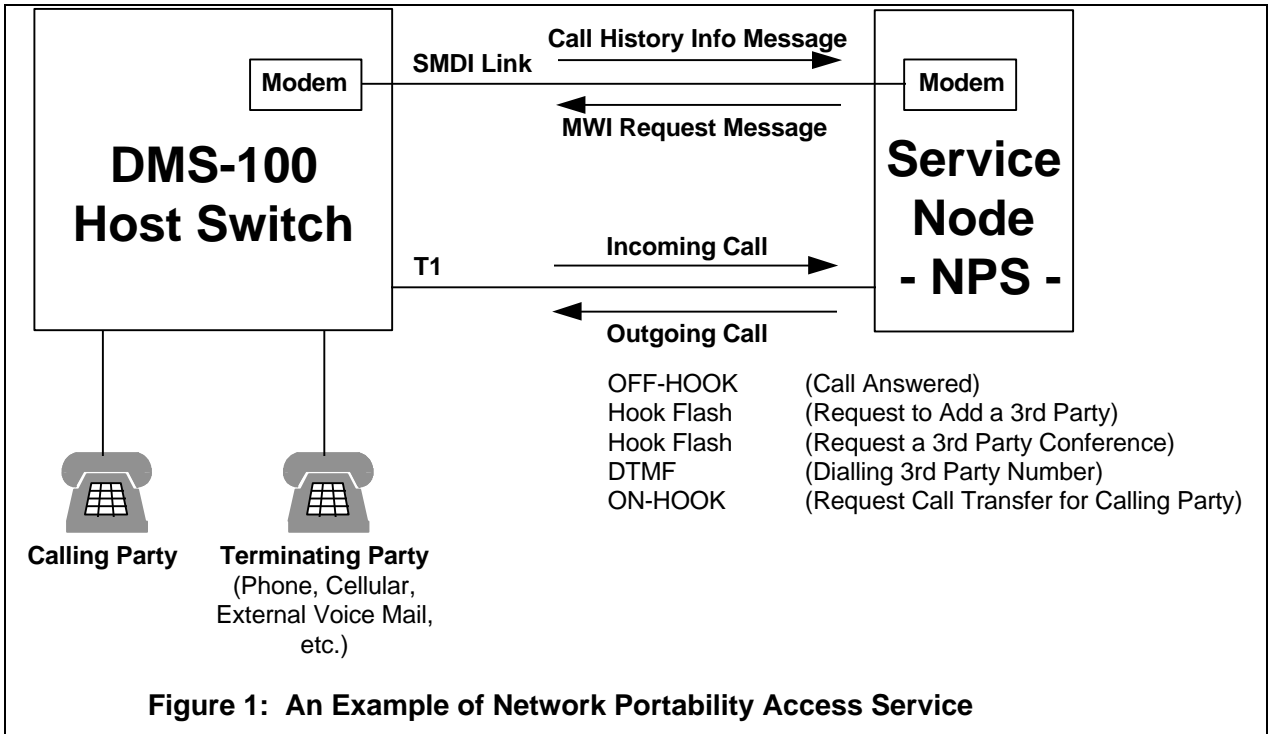



## 2.1 Interface Description

The **Service Node** interfaces the network by two ports.

### Service Node Access Channel

The analogue port facilitates the voice communication between the user and the **Service Node**. It also transmits the required signalling messages such as:

- ON-HOOK (**NPS, UVMS**)
- OFF-HOOK (**NPS, UVMS**)
- HOOK-FLASH (**NPS**)
- Dial Pulse (DP) (**NPS**)
- DTMF (**UVMS**)

Where available under tariff, T1 interface may be provided. The **Service Node** must comply with the requirements specified in Reference 5.1.

### Service Node Data Port

The messages passed over the SMDI data link contain the call related details such as:

- Identification of the called (forwarding) number.
- Calling number (if available).
- Message desk number (number of the Access Channel Group) to which the call was delivered.
- Message desk terminal number (terminal number of the Access Channel) to which the call was delivered.

These details provide the **Service Node** with information about the incoming call to assist in integration of processing, recording, and retrieval of messages. See also Reference 5.2.

## 2.2 Service Node Access Channel

The interface between the DMS-100 switch and the **Service Node** is an analogue voice channel, multiplexed to a DS1 for T1 digital interface. Details of facilities and service elements required by **Service Node** providers may be obtained from the appropriate tariffs of each individual Stentor Client Company.

## 2.3 Service Node Data Port

The Service Node Data Port, generically known as SMDI, facilitates managing of the calls received by the **Service Node**.

## 2.4 Message Waiting Indication

The **Service Node** can also originate the activation and deactivation request of the MWI to the DMS-100.

The interface requirements and the protocol associated with the MWI at the telephone set end is discussed in References 5.4 and 5.5.

The MWI command is delivered from the **Service Node**, through the network to the location (station number) designated by **Service Node**, to the MWI service subscriber. The commands are transmitted between the **Service Node** and the DMS-100 switch over the SMDI data link.

## 2.5 Voice Message Deposit

A caller that reaches a 'busy' or 'no-answer' condition and desires to leave a message for a called party provisioned with a voice mailbox will dial either a star-code, or a 7 or 10 digit access code.

## 2.6 Voice Message Retrieval

If one or more messages have been deposited for a subscriber, the network may have activated the MWI on the subscriber's line. MWI will remain active until turned off by the Service Node. This typically happens after all stored messages have been retrieved.

To retrieve a message, a telephone subscriber will dial either a star-code, or a 7 or 10 digit access number.

### 3.0 PHYSICAL CHARACTERISTICS OF THE SMDI INTERFACE

#### 3.1 SMDI Data Interface

##### Parameters

Link Type	full duplex, four wire
Transmission Scheme	analog, continuous-phase binary frequency-shift keying
Logical 1 (Mark)	1200 ± 12 Hz
Logical 0 (Space)	2200 ± 22 Hz
Transmission Rate	1200 ± 12 baud
Application of Data	serial, binary, asynchronous
Bit Error Rate	less than 1 out of every 100,000 bits at the switch interface
Phase Continuity	maintained from initial service to end of message
Transmission Level	-13.5 dBm ± 1 dBm at the switch point of data application into standard 900 Ω test termination. The loop loss is typically less than 10 dB.
Carrier Purity	Total power of all extraneous signals in the voice band, including products of non-linear or quantizing distortion, should be at least 30 dB below the power of the carrier fundamental frequency.
Source Impedance	900 Ω + 2.16 μF nominal, with a return loss satisfying requirements of Reference 5.6.

The requirements listed above are satisfied by a 202 type of modem transmission (Reference 5.6). The 900 Ω + 2.16 μF source impedance refers to the impedance that the data transmitter presents to the loop facility. The actual impedance at the terminal may vary. The received level may be affected by the terminating impedance. This must be considered in the design of the terminal. The terminal design shall adhere to requirements stated in Reference 5.1.

### 3.2 Timing Information

The mark signal (which is transmitted between the messages and the parameter data words within the messages) should be monitored for continuity by the Service Node. An interrupt of the signal of 0.008 sec or less should be ignored by the data receiver. An interrupt that exceeds 0.008 sec should cause the received data to be treated as erroneous. The message will not be retransmitted and will be lost.

The maximum interrupt time between any two successive bytes is 16.7 ms. If this interrupt time is exceeded, the message should be considered to contain an error. The message will not be retransmitted and will be lost.

### 3.3 Additional Options Available for SMDI Data Interface

The Service Node Data modem shall have the parameters listed below.

#### Parameters

Link Type	full duplex, four wire
As a network provider option, one or more of the following rates may also be supported:	2400, 4800, 9600 bits per second
Application of Data	serial, binary, asynchronous
Bit Error Rate	less than 1 out of every 100,000 bits at the switch interface
Transmission Level	-13.5 dBm $\pm$ 1 dBm at the switch point of data application into standard 900 $\Omega$ test termination. The loop loss is typically less than 10 dB.
Carrier Purity	Total power of all extraneous signals in the voice band, including products of non-linear or quantizing distortion, should be at least 30 dB below the power of the carrier fundamental frequency.
Source Impedance	900 $\Omega$ + 2.16 $\mu$ F nominal, with a return loss satisfying requirements of Reference 5.6.

The requirements listed above at speeds of 2400, 4800 and 9600 bit per second are defined by CCITT V.26, V.27 and V.29 recommendations, respectively. The  $900 \Omega + 2.16 \mu\text{F}$  source impedance refers to the impedance that the data transmitter presents to the loop facility. The actual impedance at the terminal may vary. The received level may be affected by the terminating impedance. This must be considered in the design of the terminal. The terminal design shall adhere to requirements stated in Reference 5.1.

### **3.4 Timing Information**

Timing parameters shall be in accordance with the specifications of the modem selected and the speeds chosen for the particular application.

## **4.0 DETAILED DATA PROTOCOL**

### **4.1 Characteristics**

- The protocol uses 8-bit data words (a 7-bit standard ASCII format plus one even parity bit) that are each bounded by a start bit (space) and a stop bit (mark). A combination of bytes is used to transmit the data messages.
- The data is sent with the least significant bit (LSB) transmitted first.
- Data parameters that are not recognized by the terminal should be ignored (i.e., the corresponding data should not be processed). The data will not be retransmitted.

The Call History Information Messages are transmitted from the switch to the Service Node using an asynchronous format.

### **4.2 Messages From the Network to the Message Desk**

#### **4.2.1 Call History Information Messages**

All messages on the SMDI link take on the following format:

- All messages start with a carriage return and line feed sequence.
  - cr = carriage return
  - lf = line feed
- This is followed by the letters MD (Message Desk).
- Series of seven numerical characters (gggmmmm) representing the message desk number and the message desk position (terminal) number to which the incoming call was delivered.

ggg = message desk number (001 - 063)

mmmm = message desk terminal identification (0001 -2047)

- A single character which identifies the type of forwarding used to transfer the incoming call:
  - a = D ... direct call to message desk
  - a = A ... all calls forwarded to message desk
  - a = B ... call forwarding busy line
  - a = N ... call forwarding no answer
  - \_ ... ASCII space character

If the next character is NOT a space, the next seven or ten digits represent the called station directory number from which the incoming call was forwarded to the message desk. If this information is unavailable the switch will send all zero's or blanks.

xxxxxxx = Forwarding from station number (This field may be either 7 digits or 10 digits long)

If a space was sent, either after the single letter character or after the called number, the next seven or ten digits represent the calling station's directory number. If the information is unavailable the switch will send zeros or blanks. The space character shall follow the Calling station number field in either case, as it marks the end of the fields length.

yyyyyyy = Calling station number (This field may be either 7 digits or 10 digits long)

The transmission of the carriage return and line feed characters signals the end of the data for that call. In some implementations, several extraneous characters, usually deletion characters, may be present between the line feed and (Control Y) character. These shall be ignored by the Service Node.

### 4.3 Examples of Messages to the Message Desk

#### 4.3.1 Maximum Length Message

cr  
lfMDgggmmmmmaxxxxxx\_yyyyyyy\_ Message includes calling as well as called station ID. Valid except when a = D.

cr  
lf[Control Y]

		HEX	BINARY	
cr	Carriage Return	0D	0 0 0 1 1 0 1	
lf	Line Feed	0A	0 0 0 1 0 1 0	
MD	Character "M"	4D	1 0 0 1 1 0 1	
	Character "D"	44	1 0 0 0 1 0 0	
	Message Desk Number	30	0 1 1 0 0 0 0	0
		30	0 1 1 0 0 0 0	0
		31	0 1 1 0 0 0 1	1
	Message Desk Terminal	30	0 1 1 0 0 0 0	0
		30	0 1 1 0 0 0 0	0
		31	0 1 1 0 0 0 1	1
		38	0 1 1 1 0 0 0	8
	Type of Forwarding	41	1 0 0 0 0 0 1	A
	Forwarding from Station Number	37	0 1 1 0 1 1 1	7
		37	0 1 1 0 1 1 1	7
		35	0 1 1 0 1 0 1	5
		31	0 1 1 0 0 0 1	1
		31	0 1 1 0 0 0 1	1
		32	0 1 1 0 0 1 0	2
		30	0 1 1 0 0 0 0	0
	Space Character	20	0 1 0 0 0 0 0	
	Calling Station Number	37	0 1 1 0 1 1 1	7
		37	0 1 1 0 1 1 1	7
		37	0 1 1 0 1 1 1	7
		31	0 1 1 0 0 0 1	1
		39	0 1 1 1 0 0 1	9
		35	0 1 1 0 1 0 1	5
		38	0 1 1 1 0 0 0	8
	Space Character	20	0 1 0 0 0 0 0	
cr	Carriage Return	0D	0 0 0 1 1 0 1	
lf	Line Feed	0A	0 0 0 1 0 1 0	
Control [Y]	End of Medium	19	0 0 1 1 0 0 1	



**4.3.2 Calling Station ID Unavailable**

```

cr
lfMDgggmmmmmaxxxxxxx_ _      No calling station identification.
cr
lf[Control Y]
    
```

		HEX	BINARY	
cr	Carriage Return	0D	0 0 0 1 1 0 1	
lf	Line Feed	0A	0 0 0 1 0 1 0	
MD	Character "M"	4D	1 0 0 1 1 0 1	
	Character "D"	44	1 0 0 0 1 0 0	
	Message Desk Number	30	0 1 1 0 0 0 0	0
		30	0 1 1 0 0 0 0	0
		31	0 1 1 0 0 0 1	1
	Message Desk Terminal	30	0 1 1 0 0 0 0	0
		30	0 1 1 0 0 0 0	0
		31	0 1 1 0 0 0 1	1
		38	0 1 1 1 0 0 0	8
	Type of Forwarding	41	1 0 0 0 0 0 1	A
	Forwarding from Station Number	37	0 1 1 0 1 1 1	7
		37	0 1 1 0 1 1 1	7
		35	0 1 1 0 1 0 1	5
		31	0 1 1 0 0 0 1	1
		31	0 1 1 0 0 0 1	1
		32	0 1 1 0 0 1 0	2
		30	0 1 1 0 0 0 0	0
	Space Character	20	0 1 0 0 0 0 0	
	Space Character	20	0 1 0 0 0 0 0	
cr	Carriage Return	0D	0 0 0 1 1 0 1	
lf	Line Feed	0A	0 0 0 1 0 1 0	
Control [Y]	End of Medium	19	0 0 1 1 0 0 1	

**4.3.3 Called Station ID Unavailable**

cr  
 lfMDgggmma\_yyyyyy\_ Direct call, not forwarded (a = D).  
 cr  
 lf[Control Y]

		HEX	BINARY	
cr	Carriage Return	0D	0001101	
lf	Line Feed	0A	0001010	
MD	Character "M"	4D	1001101	
	Character "D"	44	1000100	
	Message Desk Number	30	0110000	0
		30	0110000	0
		31	0110001	1
	Message Desk Terminal	30	0110000	0
		30	0110000	0
		31	0110001	1
		38	0111000	8
	Type of Forwarding	44	1000100	D
	Space Character	20	0100000	
	Calling Station Number	37	0110111	7
		37	0110111	7
		37	0110111	7
		31	0110001	1
		39	0111001	9
		35	0110101	5
		38	0111000	8
	Space Character	20	0100000	
cr	Carriage Return	0D	0001101	
lf	Line Feed	0A	0001010	
Control [Y]	End of Medium	19	0011001	

**4.3.4 Called Station ID and Calling Station ID Unavailable**

cr  
 lfMDgggmma\_ \_ Direct call, not forwarded (a = D),  
 no calling station identification.

cr  
 lf[Control Y]

		HEX	BINARY	
cr	Carriage Return	0D	0 0 0 1 1 0 1	
lf	Line Feed	0A	0 0 0 1 0 1 0	
MD	Character "M"	4D	1 0 0 1 1 0 1	
	Character "D"	44	1 0 0 0 1 0 0	
	Message Desk Number	30	0 1 1 0 0 0 0	0
		30	0 1 1 0 0 0 0	0
		31	0 1 1 0 0 0 1	1
	Message Desk Terminal	30	0 1 1 0 0 0 0	0
		30	0 1 1 0 0 0 0	0
		31	0 1 1 0 0 0 1	1
		38	0 1 1 1 0 0 0	8
	Type of Forwarding	44	1 0 0 0 1 0 0	D
	Space Character	20	0 1 0 0 0 0 0	
	Space Character	20	0 1 0 0 0 0 0	
cr	Carriage Return	0D	0 0 0 1 1 0 1	
lf	Line Feed	0A	0 0 0 1 0 1 0	
Control [Y]	End of Medium	19	0 0 1 1 0 0 1	

#### 4.4 Failure Messages for MWI Control Capability

Two types of failure messages may be provided from the switch to the message desk, invalid (INV) or blocked (BLK).

- The invalid message indicates that the directory number provided in the MWI request was invalid. This may occur if one attempts to activate or deactivate MWI for a directory number not assigned the feature, or if the directory number contains too many or too few digits.
- The blocked message indicates that the network is momentarily unable to execute the message desk request. The SMDI customer should try the transmission again later.

The following format is used for negative acknowledgments:

```
cr
lfMWIxxxxxxx_AAA
cr
lf[Control Y]
```

AAA = INV ... for invalid station number or other long term problem  
AAA = BLK ... for temporarily blocked activity  
xxxxxxx = Station Number - may be 7 or 10 digits  
\_ ... ASCII space character

**4.5 Examples of Failure Messages**

**4.5.1 Failure Message (Invalid Station Number or Other Long Term Problem)**

```

cr
lfMWIxxxxxxx_INV
cr
lf[Control Y]
    
```

		HEX	BINARY	
cr	Carriage Return	0D	0 0 0 1 1 0 1	
lf	Line Feed	0A	0 0 0 1 0 1 0	
MWI	Character "M"	4D	1 0 0 1 1 0 1	
	Character "W"	57	1 0 1 0 1 1 1	
	Character "I"	49	1 0 0 1 0 0 1	
	Station Number	37	0 1 1 0 1 1 1	7
		37	0 1 1 0 1 1 1	7
		37	0 1 1 0 1 1 1	7
		31	0 1 1 0 0 0 1	1
		39	0 1 1 1 0 0 1	9
		35	0 1 1 0 1 0 1	5
		38	0 1 1 1 0 0 0	8
	Space Character	20	0 1 0 0 0 0 0	
INV	Character "I"	49	1 0 0 1 0 0 1	
	Character "N"	4E	1 0 0 1 1 1 0	
	Character "V"	56	1 0 1 0 1 1 0	
	Deletion Character	7F	1 1 1 1 1 1 1	
	Deletion Character	7F	1 1 1 1 1 1 1	
cr	Carriage Return	0D	0 0 0 1 1 0 1	
lf	Line Feed	0A	0 0 0 1 0 1 0	
Control [Y]	End of Medium	19	0 0 1 1 0 0 1	

**4.5.2 Failure Message (Blocked for Temporarily Blocked Activity)**

```

cr
lfMWIxxxxxxx_BLK
cr
lf[Control Y]

```

		HEX	BINARY	
cr	Carriage Return	0D	0 0 0 1 1 0 1	
lf	Line Feed	0A	0 0 0 1 0 1 0	
MWI	Character "M"	4D	1 0 0 1 1 0 1	
	Character "W"	57	1 0 1 0 1 1 1	
	Character "I"	49	1 0 0 1 0 0 1	
	Station Number	37	0 1 1 0 1 1 1	7
		37	0 1 1 0 1 1 1	7
		37	0 1 1 0 1 1 1	7
		31	0 1 1 0 0 0 1	1
		39	0 1 1 1 0 0 1	9
		35	0 1 1 0 1 0 1	5
		38	0 1 1 1 0 0 0	8
	Space Character	20	0 1 0 0 0 0 0	
BLK	Character "B"	42	1 0 0 0 0 1 0	
	Character "L"	4C	1 0 0 1 1 0 1	
	Character "K"	4B	1 0 0 1 0 1 1	
	Deletion Character	7F	1 1 1 1 1 1 1	
	Deletion Character	7F	1 1 1 1 1 1 1	
cr	Carriage Return	0D	0 0 0 1 1 0 1	
lf	Line Feed	0A	0 0 0 1 0 1 0	
Control [Y]	End of Medium	19	0 0 1 1 0 0 1	

## 4.6 Messages From the Message Desk to the Network

With the optional MWI capability, two messages may be sent from the Service Node to the network using the SMDI link. These messages, OP and RMV, can activate and deactivate the MWI feature on the specified directory number. The directory number field can be provided as either a 7 digit or 10 digit number.

The network will not acknowledge receipt of these messages unless it encounters a problem when attempting to execute the request.

### 4.6.1 Request to Activate the MWI

OP:MWI\_xxxxxxx! [Control D]

		HEX	BINARY	
OP	Character "O"	4F	1 0 0 1 1 1 1	
	Character "P"	50	1 0 1 0 0 0 0	
:	Character ":"	3A	0 1 1 1 0 1 0	
MWI	Character "M"	4D	1 0 0 1 1 0 1	
	Character "W"	57	1 0 1 0 1 1 1	
	Character "I"	49	1 0 0 1 0 0 1	
	Space Character	20	0 1 0 0 0 0 0	
	Station Number	37	0 1 1 0 1 1 1	7
		37	0 1 1 0 1 1 1	7
		35	0 1 1 0 1 0 1	5
		31	0 1 1 0 0 0 1	1
		31	0 1 1 0 0 0 1	1
		32	0 1 1 0 0 1 0	2
		30	0 1 1 0 0 0 0	0
!	Character "!"	21	0 1 0 0 0 0 1	
Control [D]	End of Transmission	04	0 0 0 0 1 0 0	

## 4.6.2 Request to Deactivate the MWI

RMV:MWI\_xxxxxxx! [Control D]

		HEX	BINARY	
RMV	Character "R"	52	1 0 1 0 0 1 0	
	Character "M"	4D	1 0 0 1 1 0 1	
	Character "V"	56	1 0 1 0 1 1 0	
:	Character ":"	3A	0 1 1 1 0 1 0	
MWI	Character "M"	4D	1 0 0 1 1 0 1	
	Character "W"	57	1 0 1 0 1 1 1	
	Character "I"	49	1 0 0 1 0 0 1	
	Space Character	20	0 1 0 0 0 0 0	
	Station Number	37	0 1 1 0 1 1 1	7
		37	0 1 1 0 1 1 1	7
		35	0 1 1 0 1 0 1	5
		31	0 1 1 0 0 0 1	1
		31	0 1 1 0 0 0 1	1
		32	0 1 1 0 0 1 0	2
		30	0 1 1 0 0 0 0	0
!	Character "!"	21	0 1 0 0 0 0 1	
Control [D]	End of Transmission	04	0 0 0 0 1 0 0	



**5.0 REFERENCES****5.1 Canada, Department of Communications:**

CS-03, "Certification Standard - Standard for Terminal Equipment, Terminal Systems, Network Protection Devices, Connection Arrangements and Hearing Aids Compatibility". Current Issue

**5.2 Bellcore, Technical Reference TR-NWT-000283, Issue 2, May 1991**

"Simplified Message Desk Interface (SMDI) Generic Requirements"

**5.3 ANSI T1.403 Carrier-to-Customer Installation "DS-1 Metallic Interface Specification", Current Issue****5.4 Bell Canada, ID-0008, Visual Message Waiting Indication (VMWI), March 1991****5.5 Bell Canada, ID-0009, Audible Message Waiting Indication (AMWI), March 1991****5.6 Bell System Data Communication Technical Reference "Data Set 202S and 202T Interface Specification", Current Issue**